

Sketch Up basics

Mr Regier

Start up screen

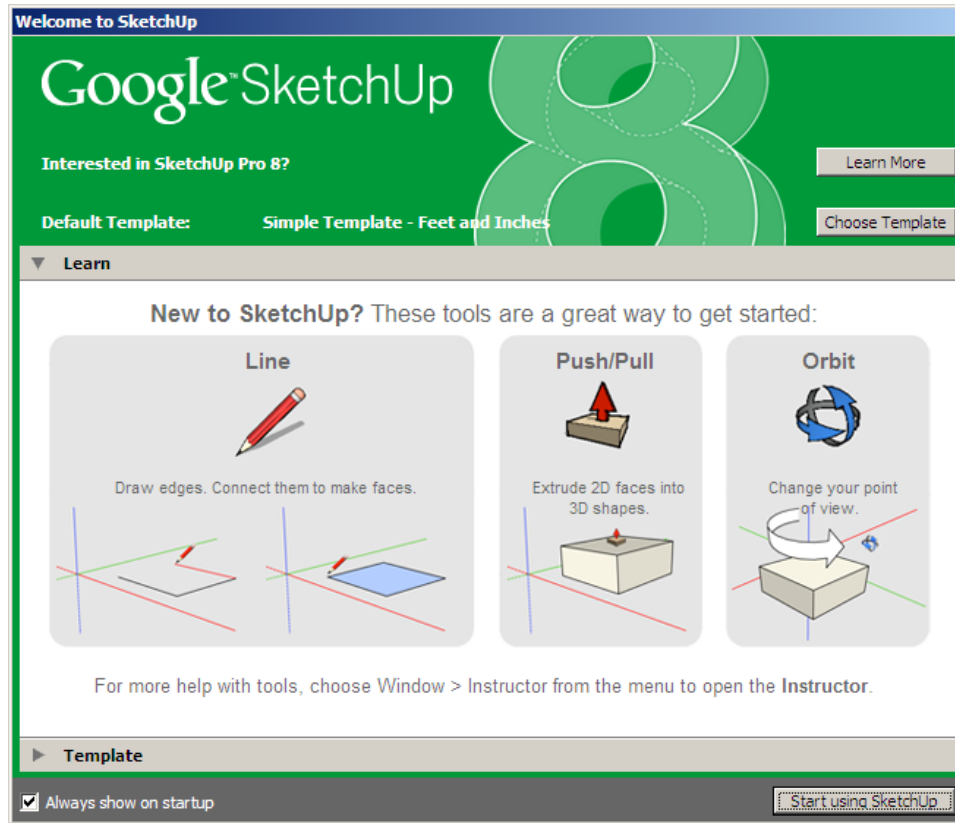

Choose Units (Often imperial)

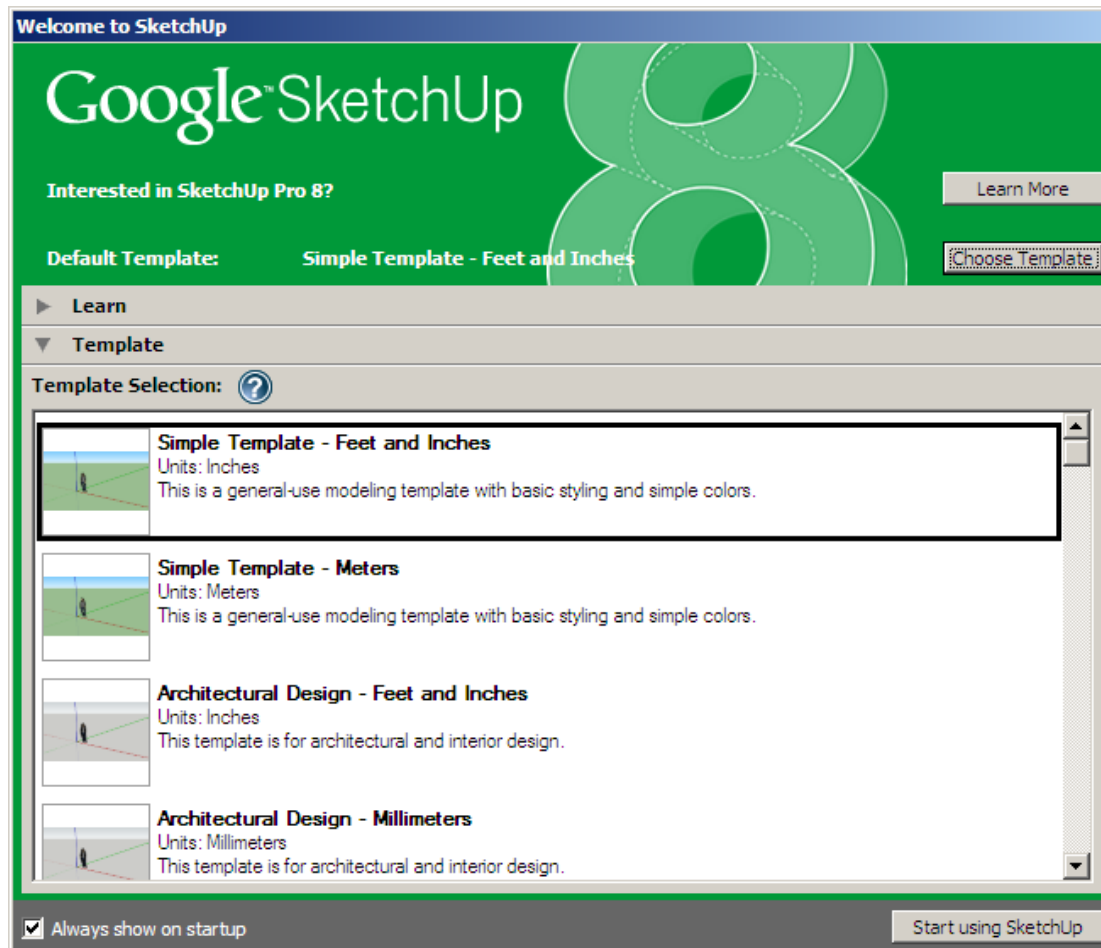

Important Conversion

- 1 foot = 12 inches
- 1 inch = 2.54 cm
- Comes from king's actual foot

Sketch Up basics



Select

Line

Rectangle

Circle

Arc

Sketch Up basics



Make
component
(once your
happy)

Eraser

Tape measure

Paint Bucket

Start drawing

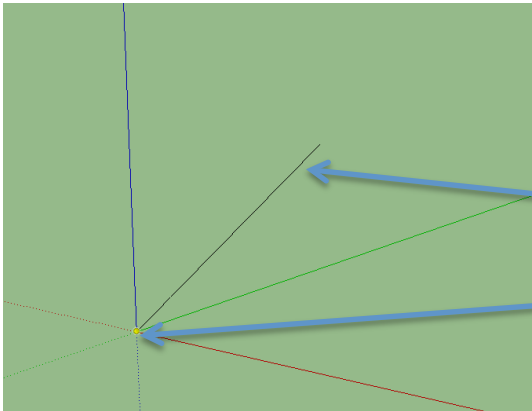

Pencil started at the origin, moved it out towards the direction I want.

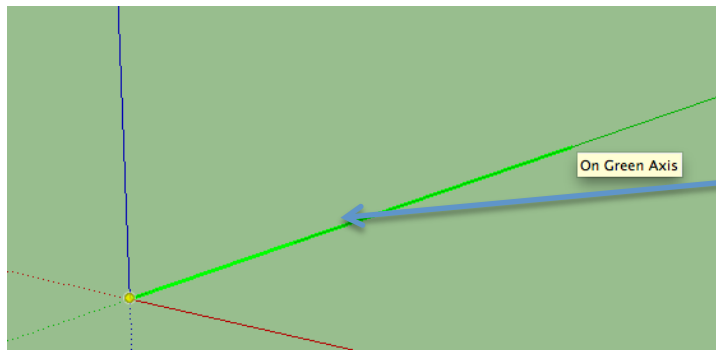

When it is going the same direction as that axis it will turn the same color

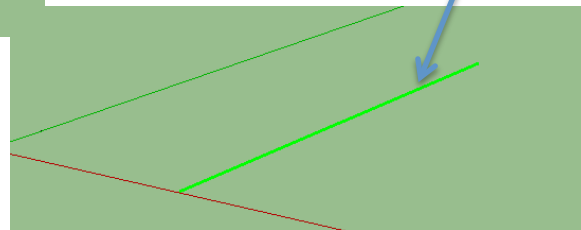

Bottom right show distance

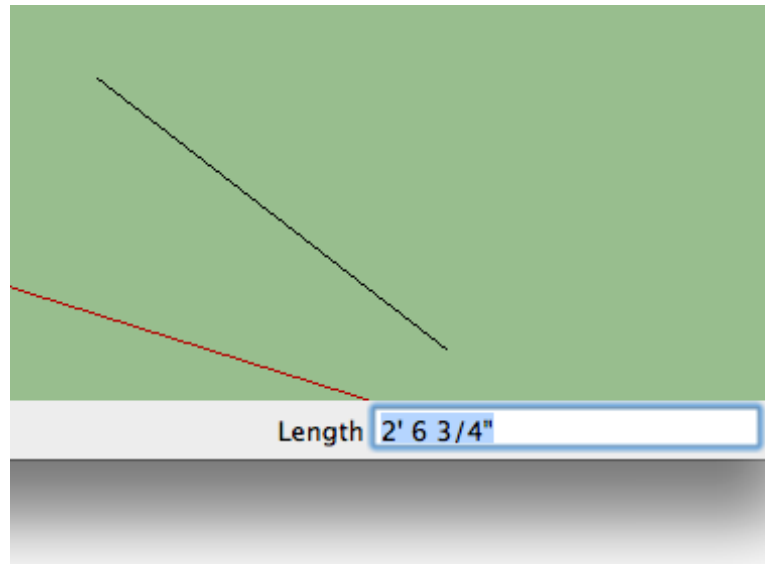

Demonstrate

- 2D object creating using pencil and box

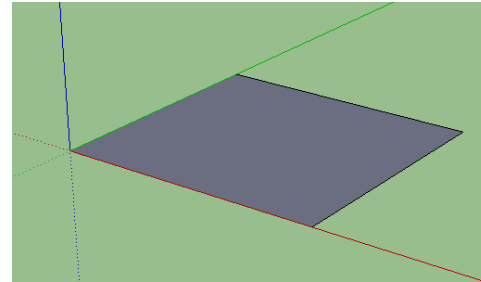

- Use Push and Pull tool

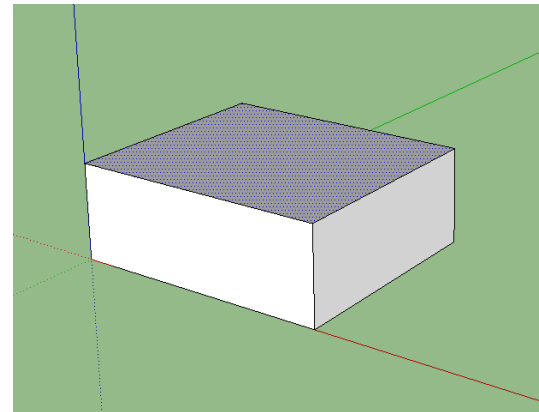

Commands

Move command

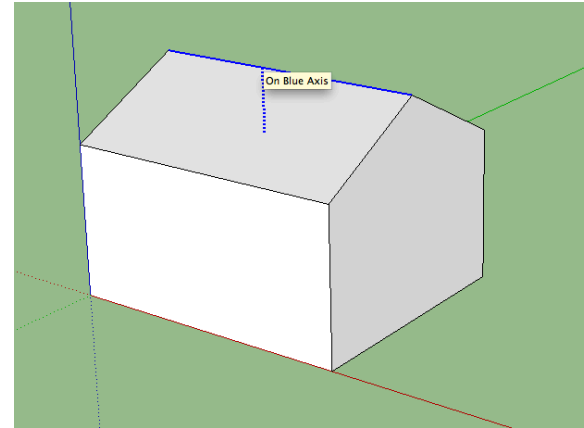

Object: Used once you are done constructing

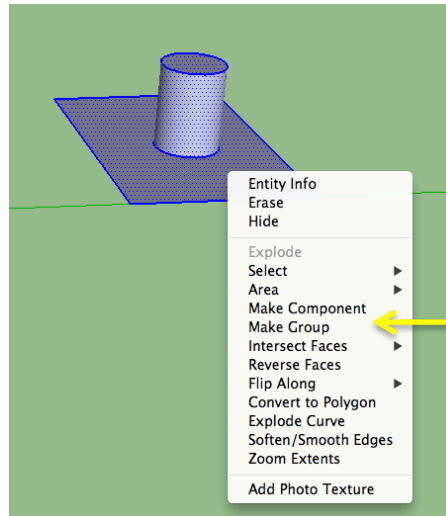

Follow me

We want to make this:

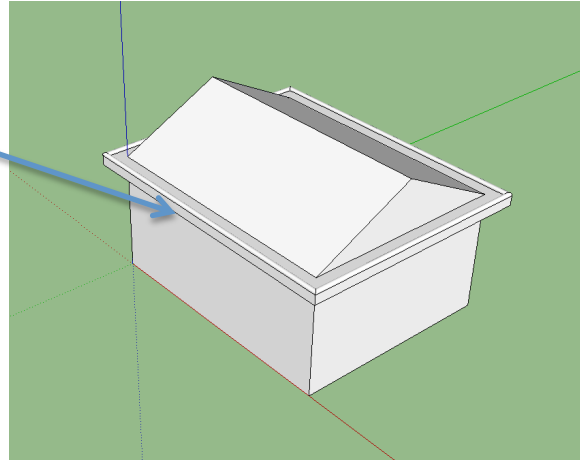

Start with this:

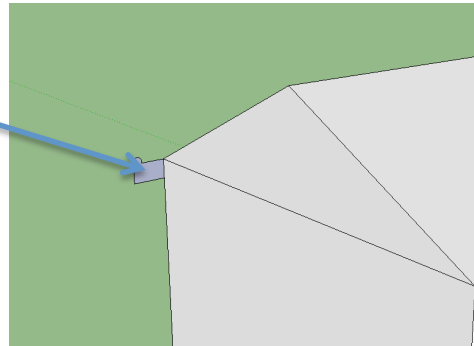

Touch the shape that you made:

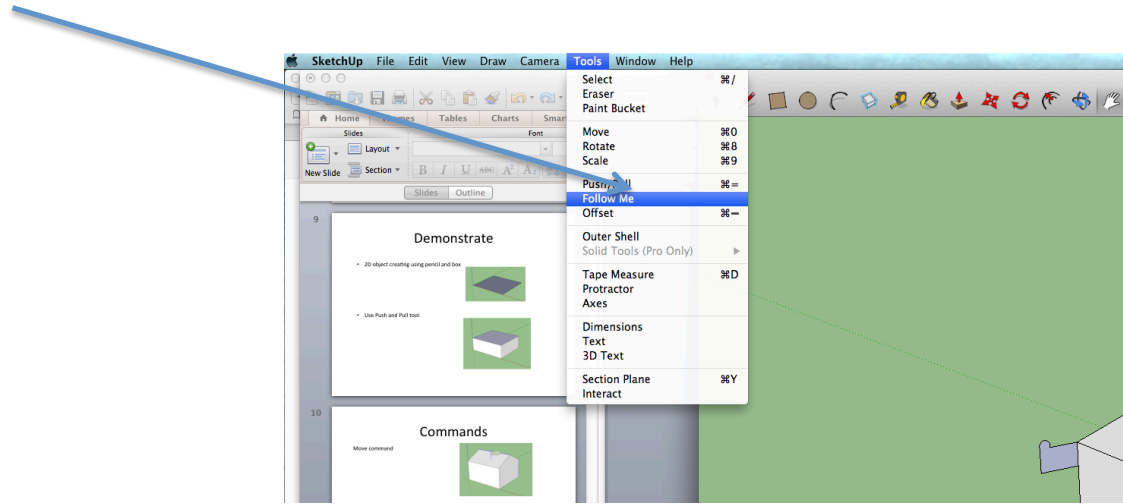

Follow the line that you want your detail to follow.

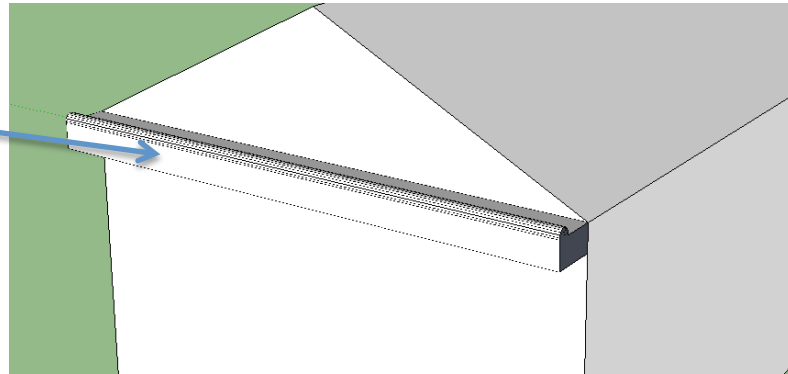

To get a detailed object from the internet



To scale objects you will have to use the ruler to measure and then you will have to know how big you want it to be.
Show example

